

**ZERO CLEARANCE**  
**FIREPLACES**

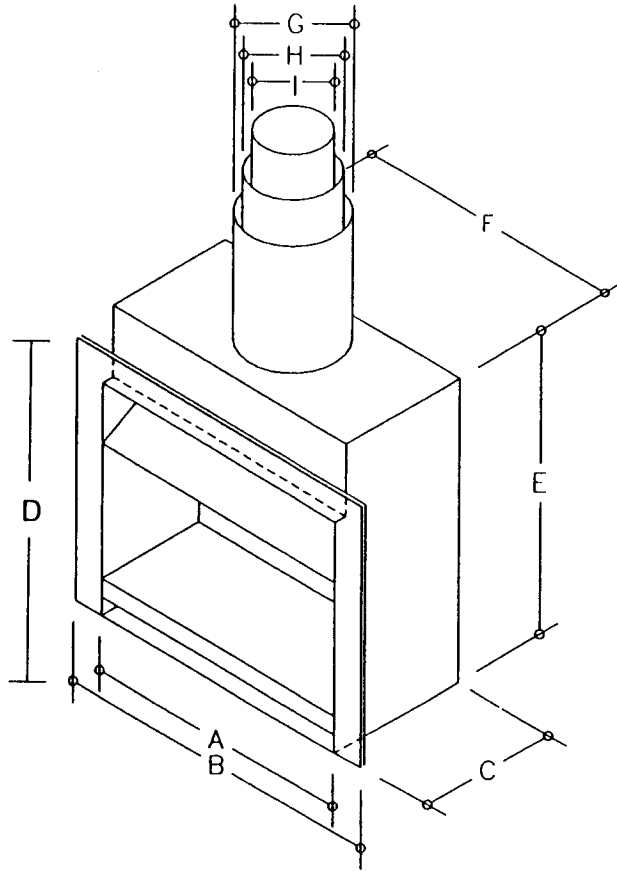

# ZERO CLEARANCE TRADITIONAL - "A"

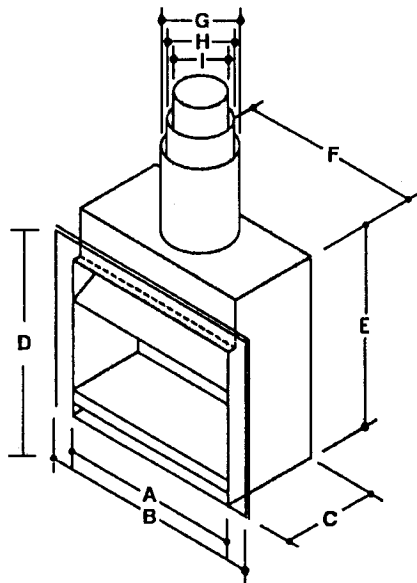

**CHART 1**

DIMENSIONS IN MILLIMETRES									
MODEL	A	B	C	D	E	F	G	H	I
500	500	700	430	725	930	650	300	250	200
600	600	800	430	725	930	750	300	250	200
700SH	700	900	430	725	930	850	300	250	200
700D	700	900	475	775	985	850	325	275	225
850	850	1050	525	825	1060	1000	350	300	250
1050	1050	1250	570	875	1160	1200	400	350	300

\*NOTE: Dimension "G" travels min. 500mm

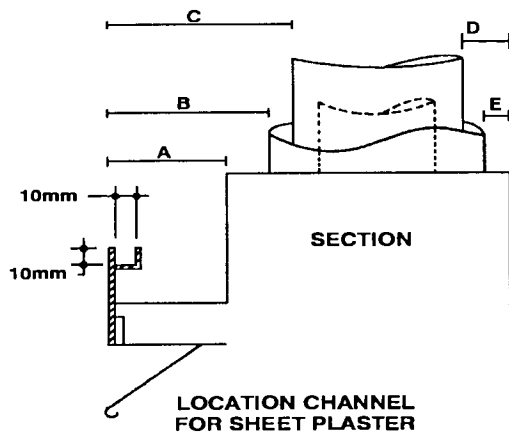

**CHART 2**

DIMENSIONS IN MILLIMETRES					
MODEL	A	B	C	D	E
		Allow 25mm clearance to combustible material	Allow 50mm clearance to combustible material		
500	50	85	110	70	45
600	50	85	110	70	45
700SH	50	85	110	70	45
700D	45	110	135	75	40
850	45	135	170	65	40
1050	45	130	105	60	40

## INSTALLATION INSTRUCTIONS

1. POSITION UNIT ON FINISHED HEARTH LEVEL. ENSURE AIR INTAKES AT BOTTOM FRONT OF UNIT ARE NOT OBSTRUCTED.
2. RIVET STAINLESS STEEL FLUE TO SPIGOT AND THEREAFTER AT EACH JOINT. FIT INNER CASINGS TO SPIGOT AND JOIN WITH THREE 25MM SELF TAPPING SCREWS THEREBY MAINTAINING AIR GAP. FIT OUTER CASING TO OUTER SPIGOT. IF FLUE IS TO BE LEFT EXPOSED TERMINATE OUTER CASING 1000MM ABOVE CEILING LINE. ENSURE THAT FLUES ARE VENTILATED AT TOP AND BOTTOM.
3. PROVIDE FLASHING WHERE FLUE PENETRATES ROOF AND FIT COWL.
4. FRAME AROUND UNIT MAINTAINING A MINIMUM CLEARANCE OF 25MM BETWEEN UNIT AND COMBUSTIBLE MATERIALS.
5. CLAD FRAME IN NOMINATED MATERIAL.
6. USE A MINIMUM OF FOUR LENGTHS OF FLUE.
7. MAINTAIN A MINIMUM CLEARANCE BETWEEN OUTER FLUE AND COMBUSTIBLE MATERIALS OF 25mm.

**ZERO CLEARANCE  
TRADITIONAL - "B"**

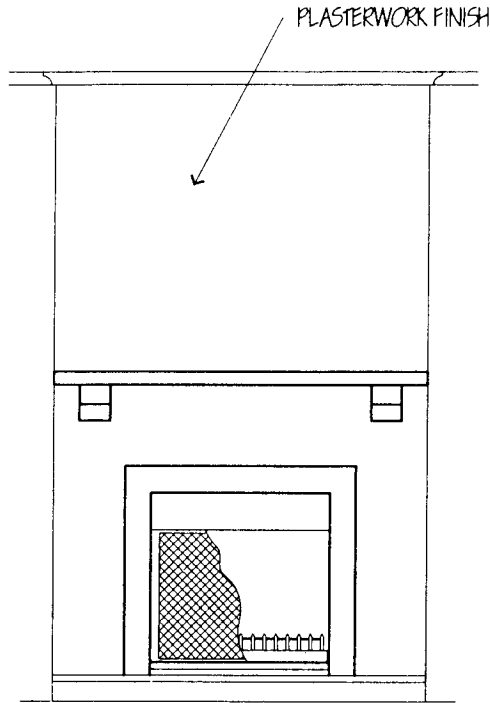

**ELEVATION**

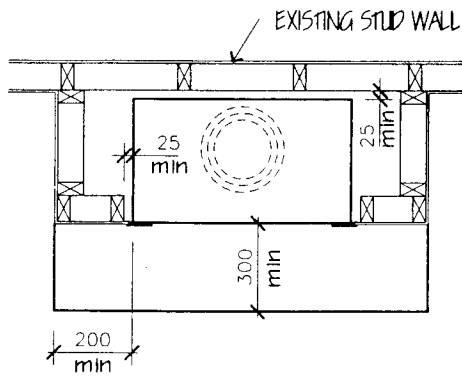

**PLAN**

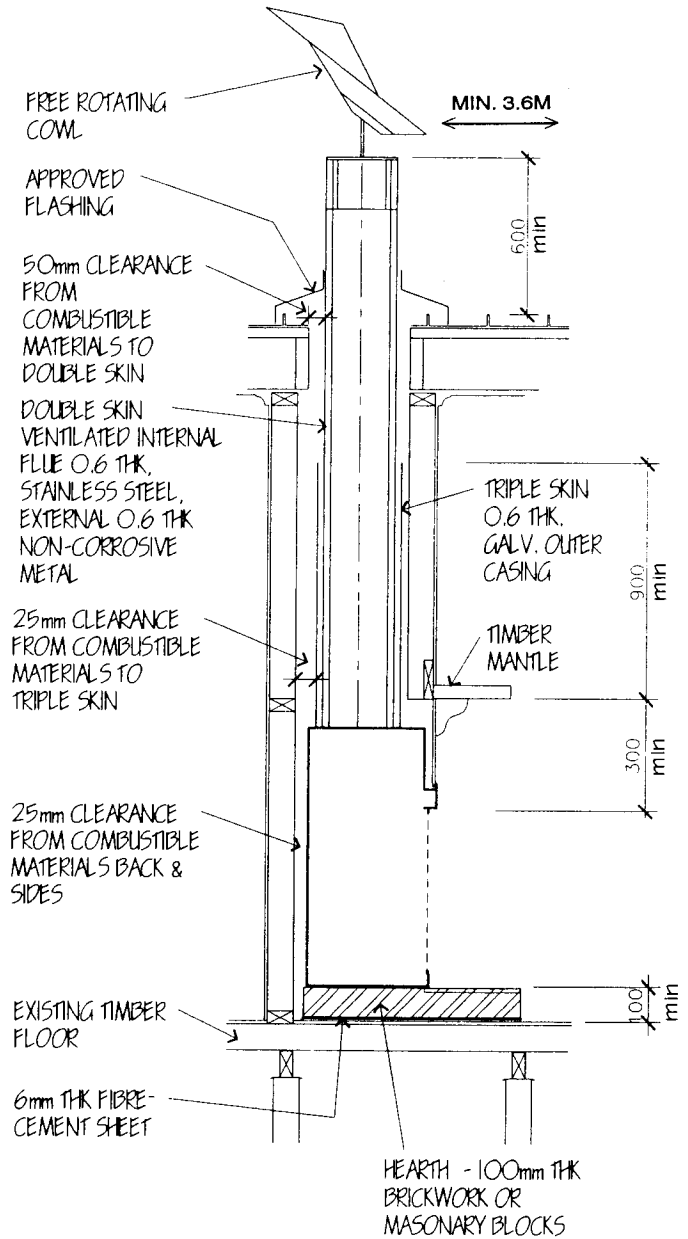

**SECTION**

**\* IMPORTANT NOTE \***  
UNIT TO BE ELEVATED TO ENSURE AIR INTAKES ARE NOT OBSTRUCTED AND TO FINISH FLUSH WITH FINISHED HEIGHT OF HEARTH.

**ZERO CLEARANCE  
TRADITIONAL - "C"**

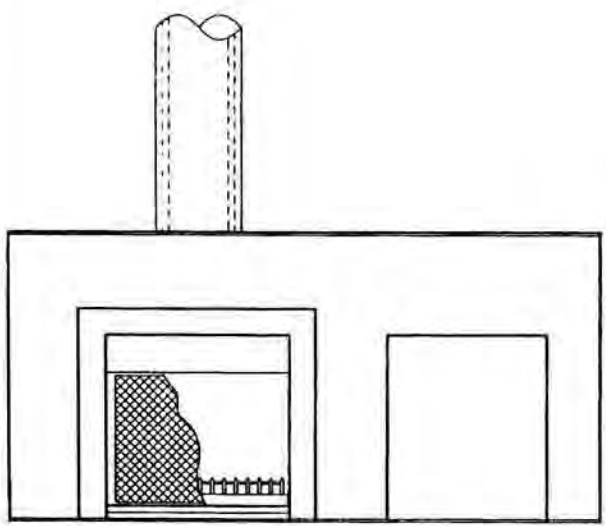

**ELEVATION**

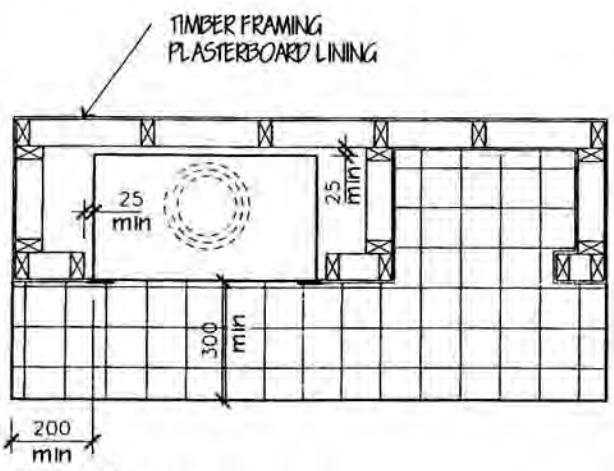

**PLAN**

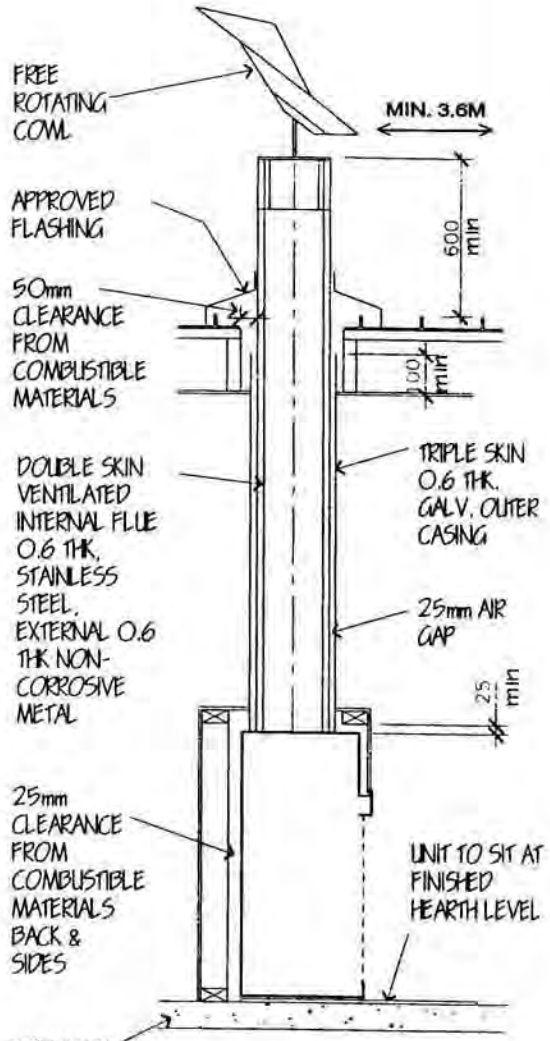

**SECTION**

**\* IMPORTANT NOTE \***  
UNIT TO BE ELEVATED TO ENSURE AIR INTAKES ARE NOT OBSTRUCTED AND TO FINISH FLUSH WITH FINISHED HEIGHT OF HEARTH.

**ZERO CLEARANCE  
FIREPLACES**

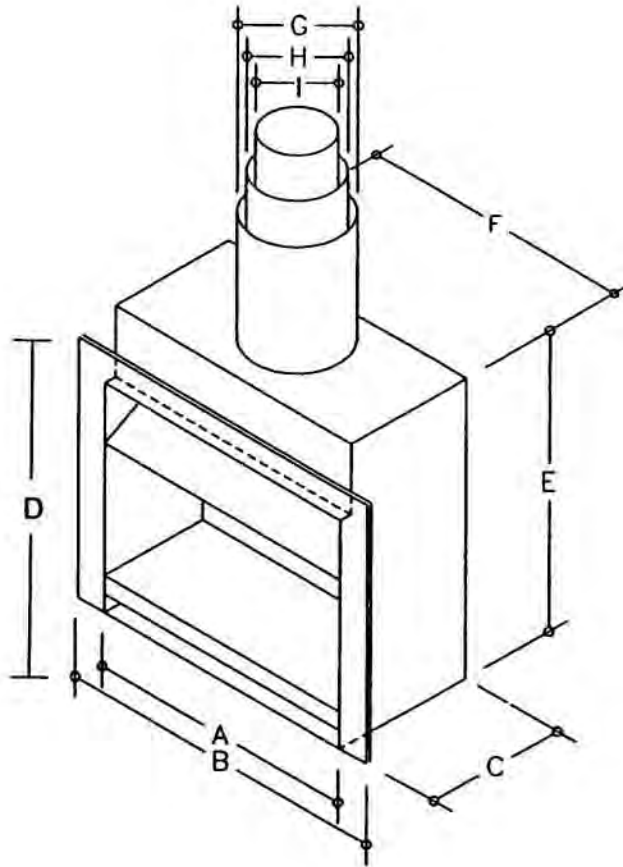

# ZERO CLEARANCE WITH FASCIA - "A"

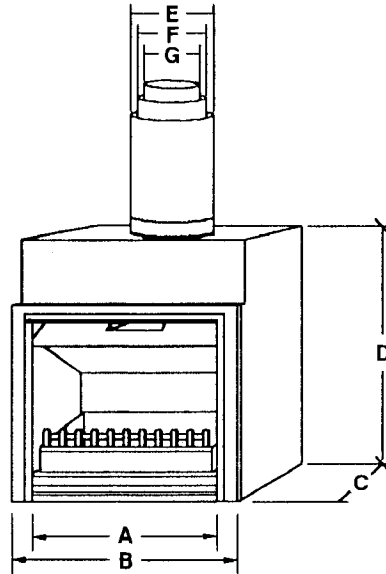

DIMENSIONS IN MILLIMETRES							
MODEL	A	B	C	D	E	F	G
440	430	560	365	820	300	250	200
500	500	700	400	930	300	250	200
600	600	800	400	930	300	250	200
700S	700	900	400	930	300	250	200

## INSTALLATION INSTRUCTIONS

1. POSITION UNIT ON FINISHED HEARTH LEVEL. ENSURE AIR INTAKES AT BOTTOM FRONT OF UNIT ARE NOT OBSTRUCTED.
2. RIVET STAINLESS STEEL FLUE TO SPIGOT AND THEREAFTER AT EACH JOINT. FIT INNER CASINGS TO SPIGOT AND JOIN WITH THREE 25MM SELF TAPPING SCREWS THEREBY MAINTAINING AIR GAP. FIT OUTER CASING TO OUTER SPIGOT. IF FLUE IS TO BE LEFT EXPOSED TERMINATE OUTER CASING 1000MM ABOVE CEILING LINE. ENSURE THAT FLUES ARE VENTILATED AT TOP AND BOTTOM, AND WHEN USING A COVER CONE DRILL A SERIES OF HOLES INTO THE OUTER FLUE BELOW THE COVER CONE TO ENSURE ADEQUATE VENTILATION.
3. PROVIDE FLASHING WHERE FLUE PENETRATES ROOF AND FIT COWL.
4. FRAME AROUND UNIT MAINTAINING A MINIMUM CLEARANCE OF 25MM BETWEEN UNIT AND COMBUSTIBLE MATERIALS.
5. CLAD FRAME IN NOMINATED MATERIAL.
6. USE A MINIMUM OF FOUR LENGTHS OF FLUE.
7. MAINTAIN A MINIMUM CLEARANCE BETWEEN OUTER FLUE AND COMBUSTIBLE MATERIALS OF 25mm.

**ZERO CLEARANCE  
WITH FASCIA - "B"**

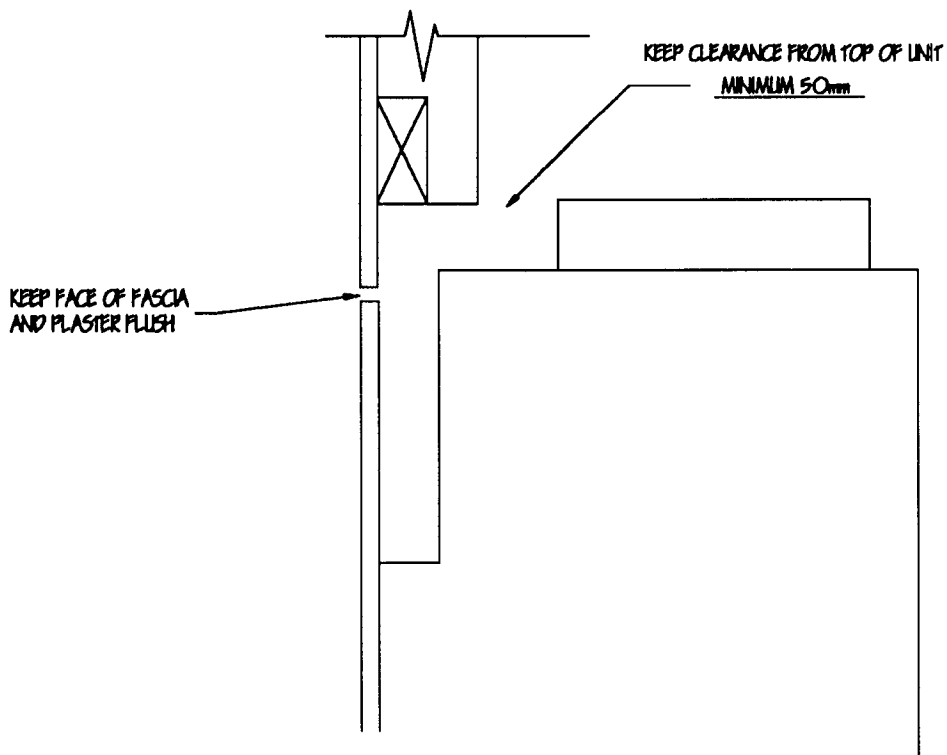
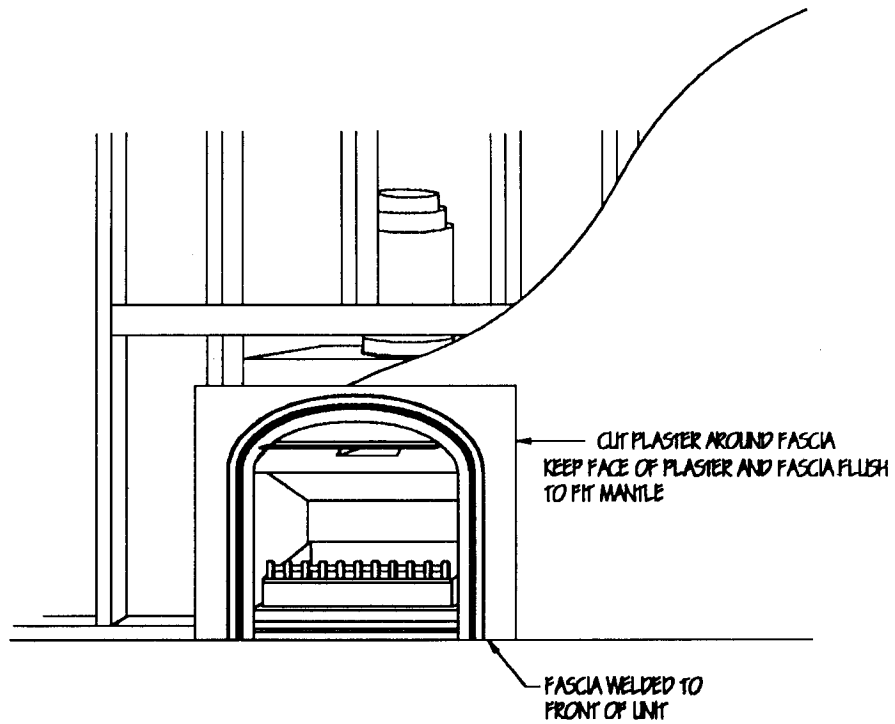

# ZERO CLEARANCE WITH FASCIA - "C"

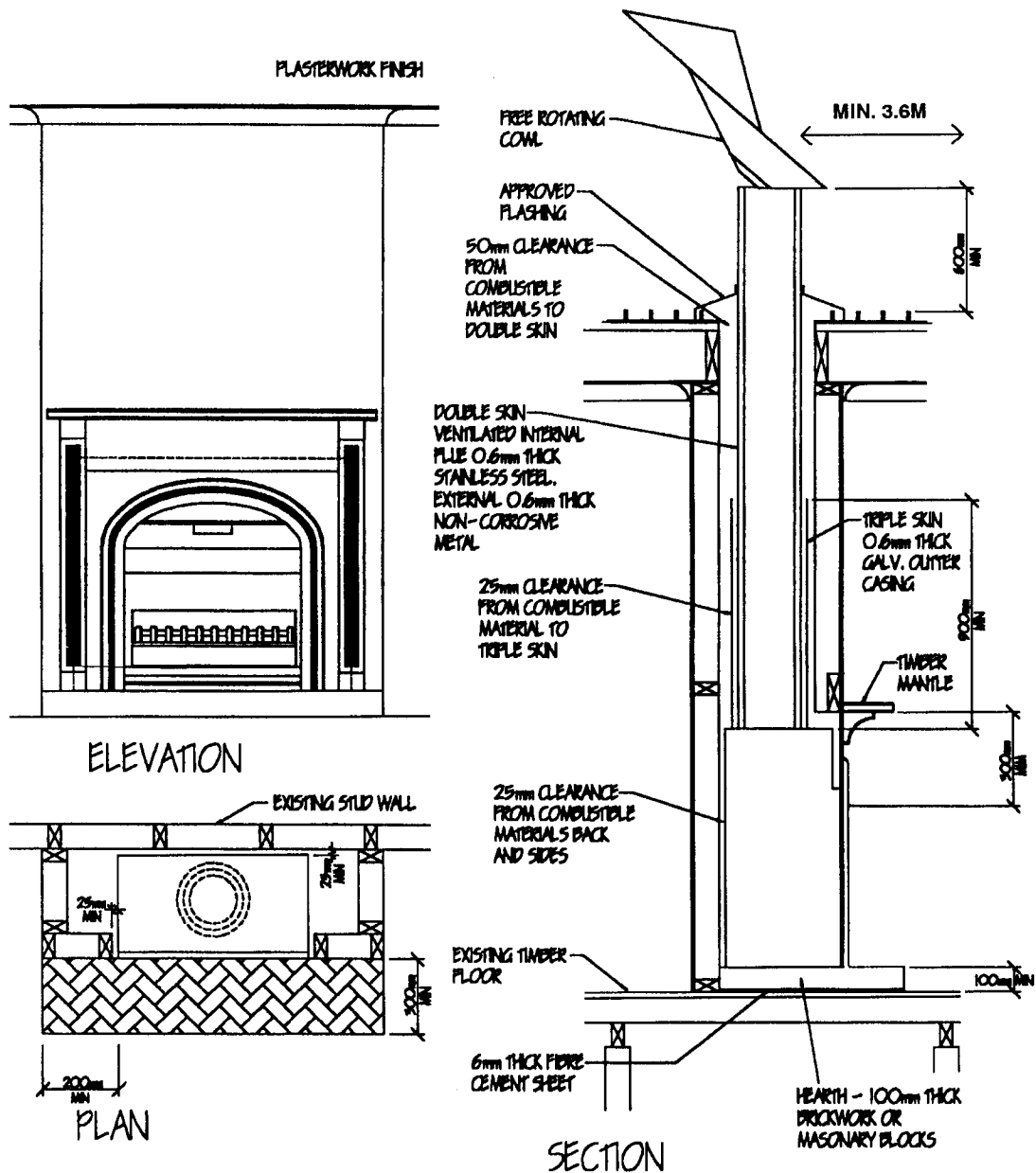

IMPORTANT NOTE  
UNIT TO BE ELEVATED TO ENSURE AIR INTAKES ARE NOT OBSTRUCTED AND TO FINISHED FLUSH WITH FINISHED HEIGHT OF HEARTH.